

SECTION A-A

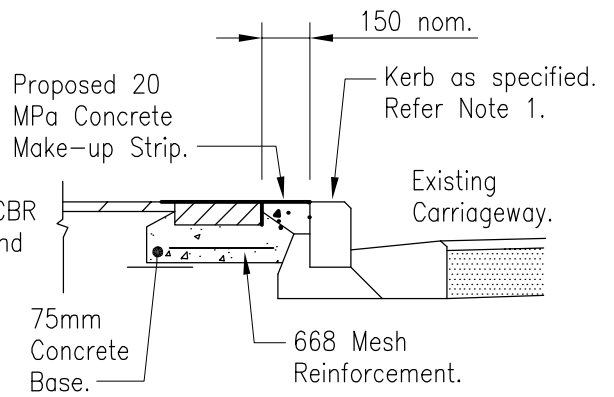

SECTION B-B

PAVER BAND AND ASPHALT CONSTRUCTION

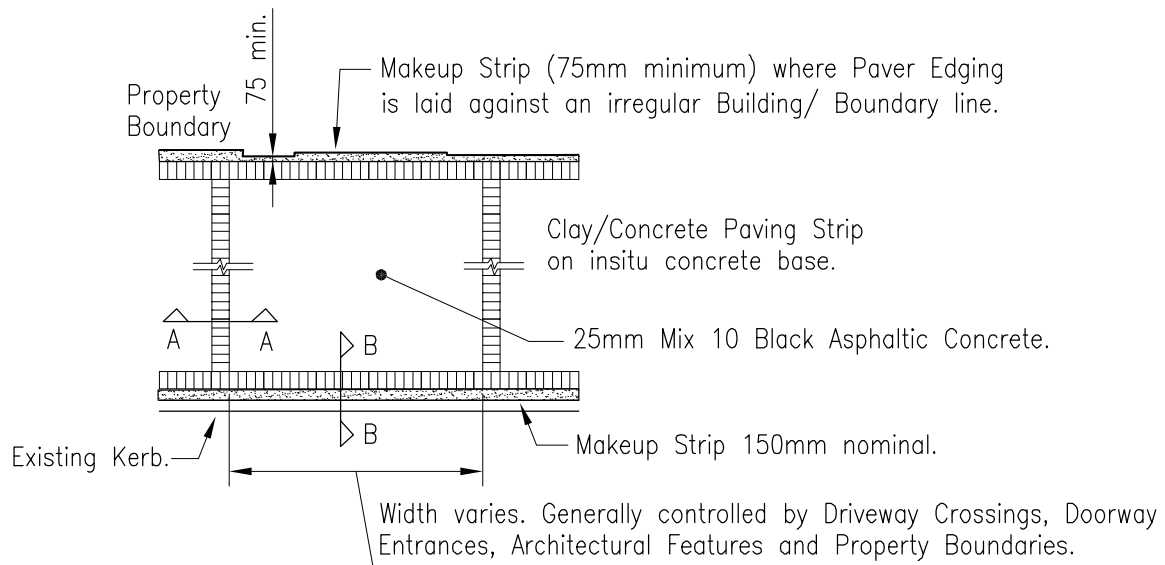

TYPICAL BAND

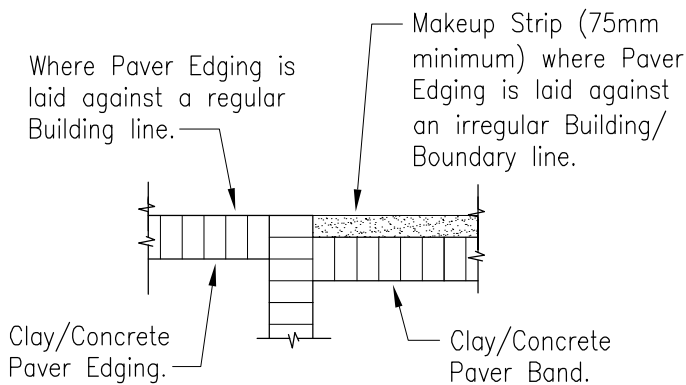

TYPICAL JUNCTION

NOTES

1. Refer to ACC Standard Detail Drawings for the following details:
Pram crossings – 2008/0608;
Kerbs and Channels – 2008/0201.
2. All Services Lids to be raised/lowered to be flush with Footpath levels.
3. All work in accordance with "NZS 3116 1991".
4. All Pavers and Architectural Concrete requires specific design and approval.
5. Refer to Drawing No. 2008/0608 for Footpath Material selection and Construction Notes.

PREPARED BY OPUS:



AUCKLAND CITY
Transport

FOOTPATH CONSTRUCTION
ASPHALT/PAVER COMBINATION

| | |
|--------------|---------|
| SCALE : | NTS |
| DRAWN : | JZW |
| ISSUE DATE : | 11/2008 |
| APPROVED : | |
| PLAN No. | ISSUE B |
| 2008/0603 | |